

INTERNAL GEAR



SENTINEL PUMPS

Sentinel pumps are manufactured by a Mexican group with over 60 years of experience transforming metals and fluid handling. Products range includes general services, industrial and process pumps designed for a range of applications.

Sentinel worldwide market has become increased through our valuable commercial partners.



Design types manufactured under Sentinel Brand: Internal Gear, Helical Gear, External Gear, Turbine and Centrifugal.

INTERNAL GEAR

Internal gear pumps are positive displacement specially designed to handle high viscosity liquids. They are equipped with casings that can be positioned to meet common piping configurations and they have only two mobile parts that make its maintenance easier.

HOW IT WORKS

Liquid enters the suction port between the rotor and idler teeth. Liquid travels through the pump between the teeth of the "gear-within-a-gear" principle. The crescent shape divides the liquid and acts as a seal between the suction and discharge ports. The pump head is now nearly flooded, just prior to forcing the liquid out of the discharge port. Intermeshing gears of the idler and rotor form locked pockets for the liquid which assures volume control. Rotor and idler teeth mesh completely to form a seal equidistant from the discharge and suction ports. This seal forces the liquid out of the discharge port.

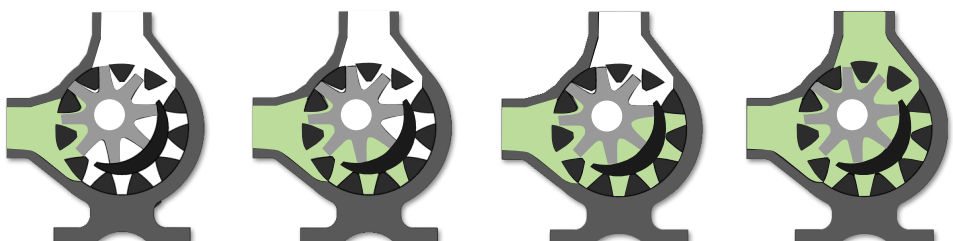

EI SERIES

Threaded bearing housing. Its large diameter allows the cartridge mechanical seal installation (except on EI-AK and EI-AL models).

The stuffing box accepts packing, numerous component mechanical seals, or a wide variety of cartridge seals (except on EI-AK and EI-AL models)

The casing can be rotated in 45° increments permitting eight different port positions.

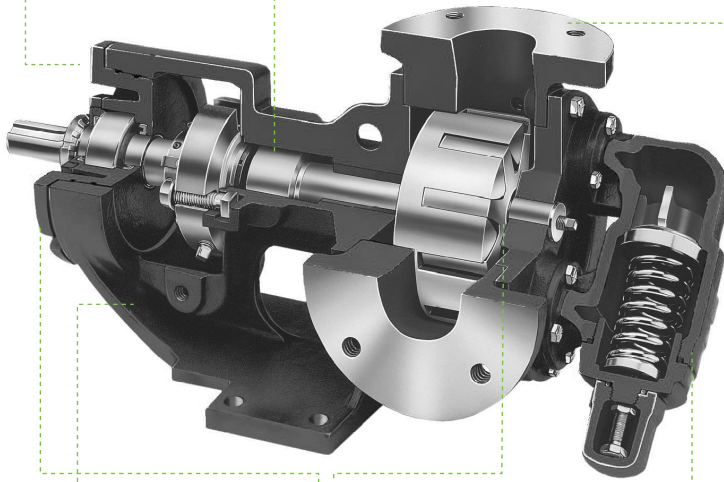

One-piece cast bracket provides rigid foundation to maximize seal and bearing life.

Rotor end clearance can be adjusted to compensate for wear or for higher temperatures or viscosities by rotating the threaded bearing housing.

Internal relief valve standard to protect the pump.

FEATURES

1. The stuffing box on all sizes accepts packing, component single mechanical seals, or cartridge seals without modifications.
2. Bearing housing provides easy rotor end clearance adjustment to compensate for viscosity or wear.
3. One-piece Bracket minimizes deflection on shaft.
4. Positive Displacement, Internal Gear pumping principle.
5. Low maintenance cost.
6. Main applications: These pumps are built to continuous or intermittent duty for such applications as circulating, transferring, or service in general industrial, petroleum uses.

GENERAL EXPLODED VIEW

EI SERIES

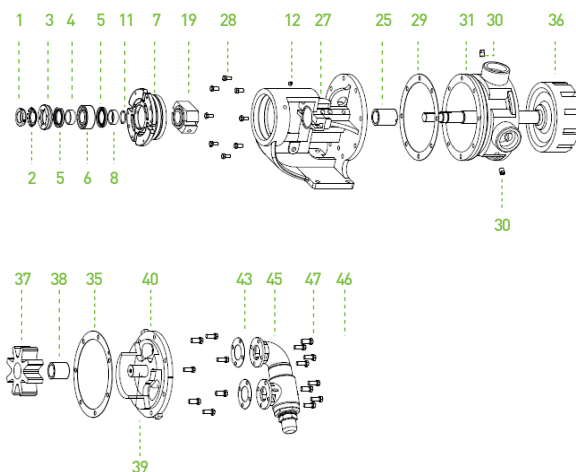

ITEM	DESCRIPTION
1	LOCKNUT
2	LOCKWASHER
3	END CAP FOR BEARING HOUSING
4	BEARING SPACER COLLAR (OUTER)
5	LIP SEAL
6	BALL BEARING
7	BEARING HOUSING
8	BEARING SPACER COLLAR (INNER)
11	RING HALF ROUND
12	GREASE FITTING
19	MECHANICAL SEAL
25	BRACKET BUSHING
27	BRACKET
28	CAPSCREW FOR BRACKET
29	BRACKET GASKET
30	PIPE PLUG
31	CASING
35	HEAD GASKET
36	ROTOR AND SHAFT
37	IDLER
38	IDLER BUSHING
39	IDLER PIN
40	HEAD
43	CAPSCREW FOR PLAIN OR VALVE TYPE HEAD
46	CAPSCREW FOR VALVE
45	RELIEF VALVE GASKET
47	RELIEF VALVE

MATERIALS OF CONSTRUCTION

EI SERIES

Bracket	Casing	Head	Rotor*	Idler*	Idler Pin/ Rotor Shaft
Cast Iron	Cast Iron	Cast Iron	Cast Iron	Cast Iron	Carbon Steel
Bushings	Packing	Mechanical Seal	Relief Valve		
Bronze / Carbon Graphite	Teflon Graphite	Buna / Viton (optional)	Iron		

* Depends on operating conditions material can be changed to carbon steel.

GENERAL OPERATING DATA

EI SERIES

Based on 750 SSU and S.G. 1.0

	EI-H	EI-HL	EI-AK	EI-AL
Port Size (in)	1 1/2	1 1/2	2	2
Flow (GPM)	17	32	54	72
Discharge Pressure (PSI)	200	200	200	200
Speed (RPM)	1750	1750	1750	1750
	EI-K	EI-KK	EI-L EI-LQ	EI-LL
Port Size (in)	2	2	2 1/2	3
Flow (GPM)	79	105	146	149
Discharge Pressure (PSI)	200	200	200	200
Speed (RPM)	780	780	640	520
	EI-LS	EI-Q	EI-QS	
Port Size (in)	3	4	6	
Flow (GPM)	209 / 137	300 / 200	470 / 315	
Discharge Pressure (PSI)	150 / 200	150 / 200	150 / 200	
Speed (RPM)	640 / 420	520 / 350	520 / 350	

EI - 4195 SERIES

Rotor end clearance can be adjusted to compensate for wear or for higher temperatures or viscosities by rotating the threaded bearing housing.

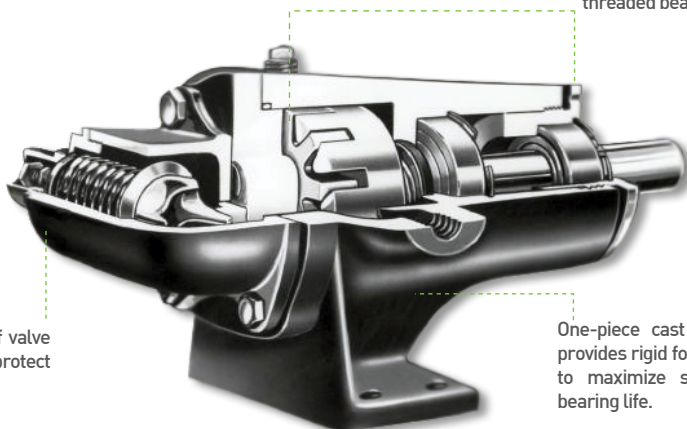

Internal relief valve standard to protect the pump.

One-piece cast bracket provides rigid foundation to maximize seal and bearing life.

FEATURES

1. All sizes of EI-4195 pumps are furnished with single mechanical seal.
2. The smaller size pumps (EI-GG4195, EI-HL4195 and EI-HJ4195) can be directly connected to either 1800 or 1200 RPM motors. The rest of the sizes can be directly connected to 1200 RPM motors (Depending on operating conditions and also 50 Hz speeds).
3. Main applications: These pumps are built to continuous or intermittent duty for such applications as circulating, transferring, or service in general industrial, petroleum uses.

GENERAL EXPLODED VIEW EI-4195 SERIES

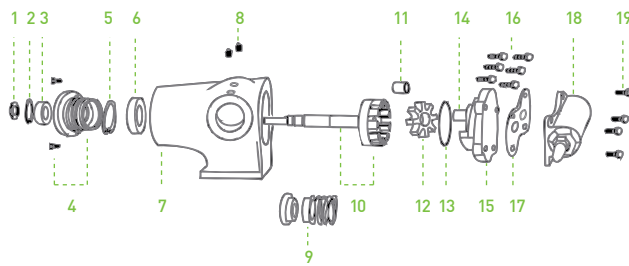

ITEM	DESCRIPTION
1	LOCKNUT
2	SNAP RING, OUTER
3	BALL BEARING, OUTER
4	BEARING HOUSING WITH SETSCREWS
5	SNAP RING, INNER
6	BALL BEARING, INNER
7	CASING
8	PIPE PLUG
9	MECHANICAL SEAL
10	ROTOR AND SHAFT
11	IDLER BUSHING
12	IDLER
13	O-RING GASKET FOR HEAD
14	IDLER PIN, PLAIN
15	HEAD
16	CAPSCREW FOR PLAIN HEAD
17	RELIEF VALVE GASKET
18	INTERNAL RELIEF VALVE
19	CAPSCREW FOR VALVE

MATERIALS OF CONSTRUCTION EI 4195 SERIES

Casing	Head	Rotor*	Idler*	Idler Pin/ Rotor Shaft	Bushings	Mechanical Seal	Relief Valve
Cast Iron	Cast Iron	Cast Iron	Cast Iron	Carbon Steel	Carbon Graphite	Buna / Viton (optional)	Iron

* Depends on model and/or operating conditions material can be changed to carbon steel.

GENERAL OPERATING DATA

EI-4195 SERIES

Based on 100 SSU and S.G. 1.0

	EI-GG4195	EI-HJ4195	EI-HL4195
Port Size (in)	1	1 1/2	1 1/2
Flow (GPM)	10	20	30
Pressure (PSI)	100	100	100
Speed (RPM)	1800	1800	1800

	EI-AS4195	EI-AK4195	EI-AL4195
Port Size (in)	2 1/2	2 1/2	3
Flow (GPM)	35	50	75
Pressure (PSI)	100	100	100
Speed (RPM)	1200	1200	1200

DIMENSIONS

EI SERIES

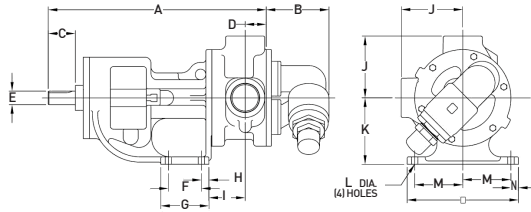

Model	A	B	C	D	E (DIA)	E (Keyway)	F	G
EI-H	13.25	2.85	1.62	1.19	0.75	0.19x0.09	2.25	3.5
EI-HL	13.25	2.85	1.62	1.19	0.75	0.19x0.09	2.25	3.5
EI-K	18.12	5.25	2.25	1.75	1.125	0.25x0.12	2.75	4.0
EI-KK	18.12	5.25	2.25	1.75	1.125	0.25x0.12	2.75	4.0
EI-L	19.62	5.43	2.25	1.75	1.125	0.25x0.12	4.0	5.38

Model	H	I	J	K	L	M	N	O
EI-H	0.62	3.38	3.0	3.5	0.47	2.75	0.62	6.75
EI-HL	0.62	3.38	3.0	3.5	0.47	2.75	0.62	6.75
EI-K	0.62	3.0	5.12	5.5	0.53	4.0	0.62	9.25
EI-KK	0.62	3.0	5.12	5.5	0.53	4.0	0.62	9.25
EI-L	0.62	3.38	6.5	7.0	0.53	4.38	0.62	10.0

Dimensions in inches

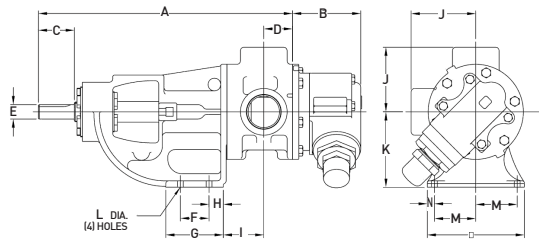

Model	A	B	C	D	E (DIA)	E (Keyway)	F	G
EI-AK	17.68	4.8	2.5	2.0	1.0	0.25x0.12	2.0	4.0
EI-AL	17.68	4.8	2.5	2.0	1.0	0.25x0.12	2.0	4.0

Model	H	I	J	K	L	M	N	O
EI-AK	1.0	2.81	4.5	5.25	0.41	2.88	0.5	6.75
EI-AL	1.0	2.81	4.5	5.25	0.41	2.88	0.5	6.75

Dimensions in inches

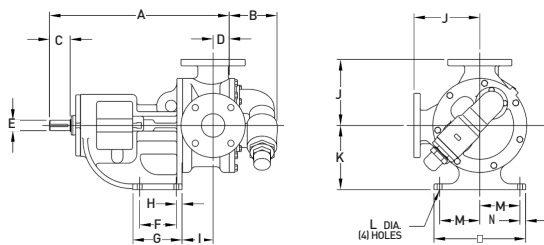

Model	A	B	C	D	E (DIA)	E (Keyway)	F	G
EI-LQ	19.62	5.43	2.25	1.75	1.125	0.25x0.12	4.0	5.38
EI-LL	20.12	5.43	2.25	2.25	1.125	0.25x0.12	4.0	5.38
EI-LS	21.69	5.43	3.5	2.44	1.44	0.38x0.19	4.0	5.38
EI-Q	26.75	8.25	4.5	3.0	1.94	0.50x0.25	4.0	6.0

Model	H	I	J	K	L	M	N	O
EI-LQ	0.62	3.38	7.19	7.0	0.53	4.38	0.62	10.0
EI-LL	0.62	3.38	7.19	7.0	0.53	4.38	0.62	10.0
EI-LS	0.62	4.75	7.19	7.0	0.53	4.38	0.62	10.0
EI-Q	1.0	6.62	8.25	8.75	0.69	4.12	.75	10.0

Dimensions in inches

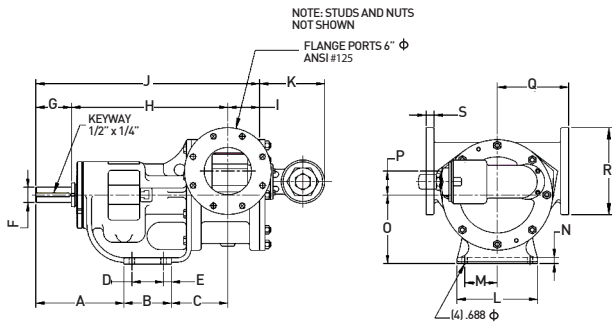

Model	A	B	C	D	E	F	G	H	I	J
EI-QS	11.13	6.00	7.12	4.00	1.00	1.93	4.50	19.75	4.00	28.25

Model	K	L	M	N	O	P	Q	R	S
EI-QS	8.25	10.00	4.12	0.80	8.75	3.00	9.00	11.00	1.0

Dimensions in inches

EI-4195 SERIES

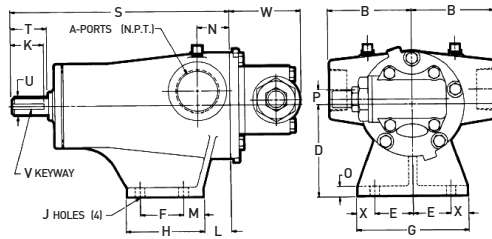

Model	A	B	D	E	F	G	H	J	K	L
EI-GG4195	1.0	2.75	2.75	1.62	1.31	4.0	2.44	0.34	0.94	0.03
EI-HJ4195	1.50	3.75	4.12	1.75	2.0	5.0	3.5	0.41	1.5	1.25
EI-HL4195	1.50	3.75	4.12	1.75	2.0	5.0	3.5	0.41	1.5	1.25

Model	M	N	O	P	S	T	U	V	W	X
EI-GG4195	0.66	1.21	0.31	0.62	7.31	1.12	0.5	FLAT	2.66	0.38
EI-HJ4195	0.88	1.5	0.44	0.62	10.0	1-62	0.75	0.19X0.09	3.28	0.75
EI-HL4195	0.88	1.5	0.44	0.62	10.0	1-62	0.75	0.19X0.09	3.28	0.75

Dimensions in inches

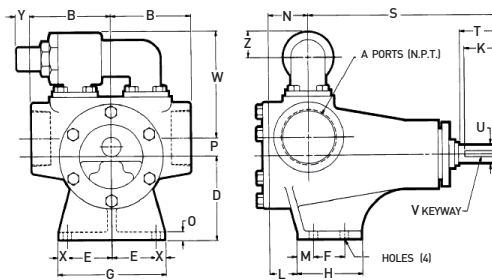

Model	A	B	D	E	F	G	H	J	K	L	M
EI-AS4195	2.5	5.0	5.25	2.88	2.0	6.75	4.0	0.41	2.25	1.25	1.0
EI-AK4195	2.5	5.0	5.25	2.88	2.0	6.75	4.0	0.41	2.25	1.25	1.0
EI-AL4195	3.00	5.0	5.25	2.88	2.0	6.75	4.0	0.41	2.25	1.75	1.0

Model	N	O	P	S	T	U	V	W	X	Y	Z
EI-AS4195	2.0	0.44	1.12	12.12	2.5	1.0	0.25X0.12	7.0	0.5	1.0	1.72
EI-AK4195	2.0	0.44	1.12	12.12	2.5	1.0	0.25X0.12	7.0	0.5	1.0	1.72
EI-AL4195	2.5	0.44	1.12	12.12	2.5	1.0	0.25X0.12	7.0	0.5	1.0	1.72

Dimensions in inches

SENTINEL INTERNAL GEAR

INTERNATIONAL SALES:

Tel : + 52 555 715 16 82

internationalsales@imbo.com.mx

Emiliano Zapata 41, Col San Juan Ixhuatepec,
Tlalnepantla, Edo. de México

